

Turnkey System Solutions for Your Production

# Gantry Robots

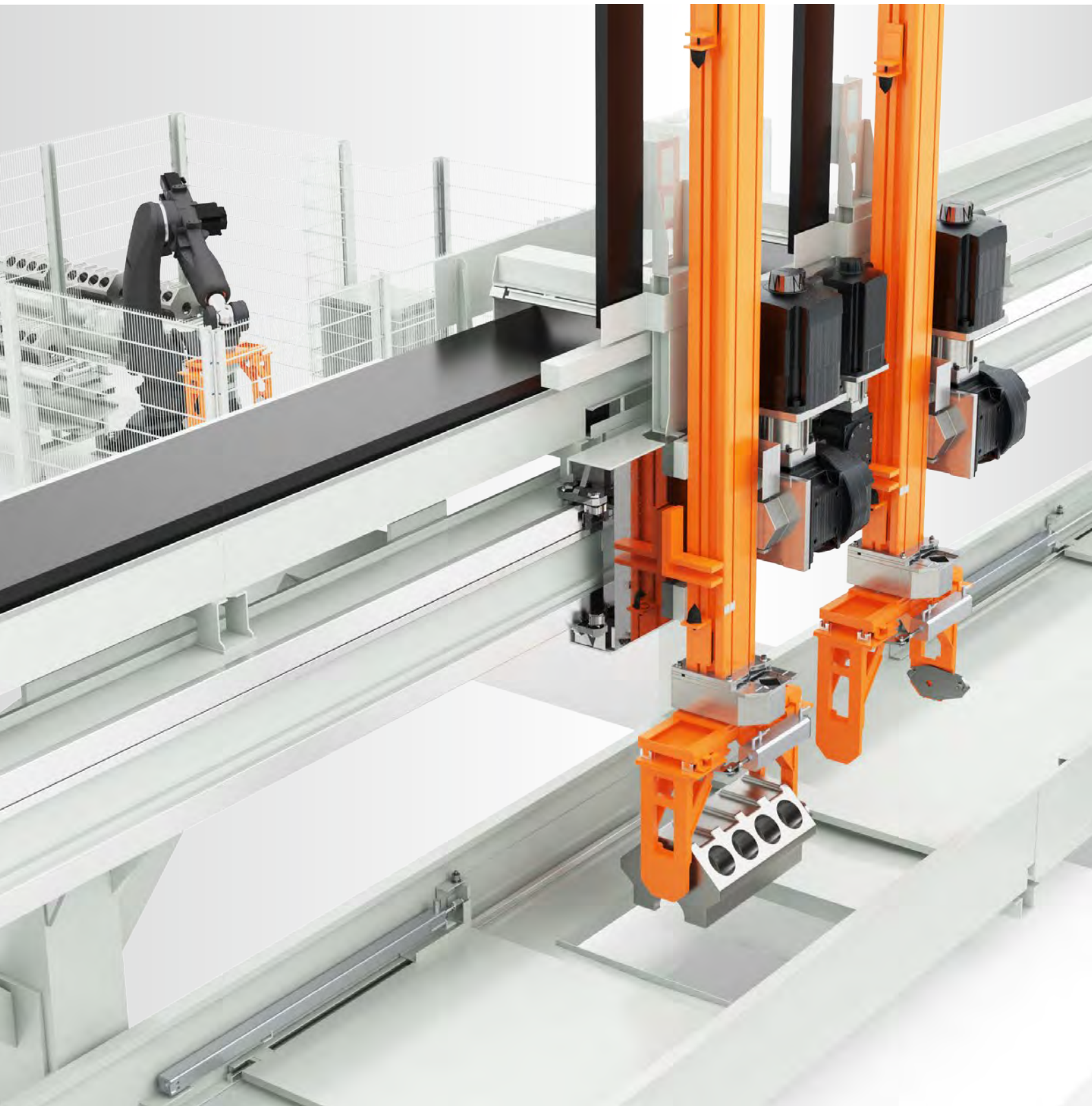

**LIEBHERR**

# Liebherr Gantry Robots

Liebherr offers a wide range of automation systems that enable modern high-efficiency production. The emphasis here is on economy, ease of use, quality, and reliability in combination with a high degree of flexibility. The production range comprises gantry robots, conveying systems, storage systems, pallet handling systems, and robot integration.

As a pioneer in gantry robot technology, Liebherr has established itself as a partner of the automotive industry since 1970. To date, over 20,000 machines around the world have been automated with gantry robot technology.

Liebherr gantry robots can be deployed in a variety of ways: For transporting, palletizing, goods handling, loading and unloading, or storing.

Liebherr offers a gantry modular system for all sizes allowing a large spectrum of components to be covered.

## **Economy**

An essential prerequisite for economical production is the optimum supply of the processing machine. Hand-loaded or semi-automatic machines only meet this requirement to a limited extent.

Liebherr gantry robots increase the productivity and efficiency of manufacturing processes, thus securing the economy over the long term. Thanks to the application-based design of the axis configuration and gripping technology, Liebherr gantry robots offer maximum availability and output with minimum maintenance. The systems are flexible and can be extended if requirements change.

## **Flexibility**

With its modular design, the Liebherr gantry robots are particularly flexible and versatile. Liebherr finds the optimal solution for every job. With a high level of in-house production, Liebherr is able to implement customized requirements quickly and competently.

## **User-Friendliness**

An optimal working environment is the basis for a smooth manufacturing process.

Top loading allows unrestricted access to the plant, the floor area remains free for use. The optional software solution LMS 4.0, for monitoring and supporting manufacturing processes, allows the user to optimally control the manufacturing process. The machine status can be displayed on large screens or mobile end devices via a graphic interface.

## **Quality and Reliability**

Quality is the ultimate priority at Liebherr. Every production stage is consistently monitored in order to achieve optimum results at all times and to ensure the reliability and long life of the products.

The quality management system of the entire manufacturing process at Liebherr-Verzahntechnik GmbH is certified in accordance with DIN EN ISO 9001:2008 and OHSAS 18001. Moreover, many years of experience and state-of-the-art technologies flow into product development.

# Applications and Industry Solutions



## Liebherr Gantry Robots are Used in diverse Industries.

- Automotive and automotive supplier industry
- Commercial vehicle industry
- Agricultural and construction machines
- Aerospace industry
- Rail vehicle industry
- Machine construction
- Wind energy
- Mining
- Crane and hoisting technology
- Household appliances and electrical equipment
- and many more ...

# Linear Gantry Robot

Due to its flexible modular system, all sizes can be tailored optimally to the respective requirement. Linear gantry robots from Liebherr are available in five sizes for transport loads from 0.5 kg up to 1500 kg and perform a wide range of automation tasks. Via standardized interfaces the gantry robots can be put together up to lengths over 100 m.



## PP 10

Max. payload	kg	40
Max. carrier length X	m	12
Max. stroke Z	mm	700
Max. traverse speed X	m/min	120
Max. acceleration X	m/s <sup>2</sup>	4.0
Max. traverse speed Z	m/min	40
Max. acceleration Z	m/s <sup>2</sup>	5.0
Repeat accuracy/axis +/-	mm	0.1



## LP 10

Max. payload	kg	40
Max. carrier length X	m	50
Max. stroke Z	mm	1,500
Max. traverse speed X	m/min	180
Max. acceleration X	m/s <sup>2</sup>	4.0
Max. traverse speed Z	m/min	120
Max. acceleration Z	m/s <sup>2</sup>	5.0
Repeat accuracy/axis +/-	mm	0.1



## LP 20

Max. payload	kg	160
Max. payload in telescopic version	kg	110
Max. carrier length X	m	120
Max. stroke Z	mm	2,000
Max. traverse speed X	m/min	180
Max. acceleration X	m/s <sup>2</sup>	4.0
Max. traverse speed Z	m/min	120
Max. acceleration Z	m/s <sup>2</sup>	5.0
Repeat accuracy/axis +/-	mm	0.1



## LP 20 HD\*

Max. payload	kg	240
Max. carrier length X	m	120
Max. stroke Z	mm	2,000
Max. traverse speed X	m/min	180
Max. acceleration X	m/s <sup>2</sup>	4.0
Max. traverse speed Z	m/min	120
Max. acceleration Z	m/s <sup>2</sup>	5.0
Repeat accuracy/axis +/-	mm	0.1

\*Version with higher load bearing capacity



### LP 100

Max. payload	kg	220
Max. carrier length X	m	120
Max. stroke Z	mm	2,000
Max. traverse speed X	m/min	180
Max. acceleration X	m/s <sup>2</sup>	2.5
Max. traverse speed Z	m/min	120
Max. acceleration Z	m/s <sup>2</sup>	5.0
Repeat accuracy/axis +/-	mm	0.1



### LP 100 HS\*\*

Max. payload	kg	220
Max. carrier length X	m	120
Max. stroke Z	mm	2,000
Max. traverse speed X	m/min	300
Max. acceleration X	m/s <sup>2</sup>	4.5
Max. traverse speed Z	m/min	120
Max. acceleration Z	m/s <sup>2</sup>	5.0
Repeat accuracy/axis +/-	mm	0.1



### LP 100 HD\*

Max. payload	kg	280
Max. carrier length X	m	120
Max. stroke Z	mm	2,000
Max. traverse speed X	m/min	180
Max. acceleration X	m/s <sup>2</sup>	2.5
Max. traverse speed Z	m/min	120
Max. acceleration Z	m/s <sup>2</sup>	5.0
Repeat accuracy/axis +/-	mm	0.1



### LP 200

Max. payload	kg	300
Max. payload in telescopic version	kg	220
Max. carrier length X	m	120
Max. stroke Z	mm	2,000
Max. traverse speed X	m/min	180
Max. acceleration X	m/s <sup>2</sup>	3.0
Max. traverse speed Z	m/min	120
Max. acceleration Z	m/s <sup>2</sup>	5.0
Repeat accuracy/axis +/-	mm	0.1

\*Version with higher load bearing capacity  
 \*\*Version with higher speed



### LP 200 HD\*

Max. payload	kg	420
Max. carrier length X	m	120
Max. stroke Z	mm	2,200
Max. traverse speed X	m/min	180
Max. acceleration X	m/s <sup>2</sup>	3.0
Max. traverse speed Z	m/min	120
Max. acceleration Z	m/s <sup>2</sup>	5.0
Repeat accuracy/axis +/-	mm	0.1



### LP 200 STL\*

Max. payload	kg	600
Max. payload in telescopic version	kg	400
Max. carrier length X	m	120
Max. stroke Z	mm	2,200
Max. traverse speed X	m/min	180
Max. acceleration X	m/s <sup>2</sup>	3.0
Max. traverse speed Z	m/min	120
Max. acceleration Z	m/s <sup>2</sup>	3.0
Repeat accuracy/axis +/-	mm	0.1



### LP 2000

Max. payload	kg	1,100
Max. carrier length X	m	120
Max. stroke Z	mm	2,200
Max. traverse speed X	m/min	120
Max. acceleration X	m/s <sup>2</sup>	2.0
Max. traverse speed Z	m/min	90
Max. acceleration Z	m/s <sup>2</sup>	1.5
Repeat accuracy/axis +/-	mm	0.1



### LP 2000 HD\*

Max. payload	kg	1,500
Max. carrier length X	m	120
Max. stroke Z	mm	2,200
Max. traverse speed X	m/min	120
Max. acceleration X	m/s <sup>2</sup>	2.0
Max. traverse speed Z	m/min	90
Max. acceleration Z	m/s <sup>2</sup>	1.5
Repeat accuracy/axis +/-	mm	0.1

\*Version with higher load bearing capacity

# Gantry Area Robots



The high precision Liebherr gantry area robots are deployed in work areas in which Liebherr linear robots can no longer perform their duty. The modular structure guarantees the highest level of flexibility in the realization of complex customer requirements.

LPR 200

		PPR 10	LPR 20	LPR 20 HD*	LPR 200	LPR 200 HD*	LPR 200 STL*	LPR 2000	LPR 2000 HD*
Max. payload	kg	40	160	240	300	420	600	1,100	1,500
Max. payload (telescopic version)	kg	-	110	-	220	-	400	-	-
Max. carrier length X	m	12	60	60	60	60	60	60	60
Max. travel path/carrier length Y	m	6	8	8	10	10	10	12	12
Max. stroke Z	mm	700	2,000	2,000	2,200	2,200	2,200	2,200	2,200
Max. traverse speed X	m/min	120	180	180	180	180	180	120	120
Max. acceleration X	m/s <sup>2</sup>	4.0	4.0	4.0	3.0	3.0	3.0	2.0	2.0
Max. traverse speed Y	m/min	120	120	120	120	120	120	120	120
Max. acceleration Y	m/s <sup>2</sup>	4.0	3.0	3.0	3.0	3.0	3.0	2.0	2.0
Max. traverse speed Z	m/min	40	120	120	120	120	120	120	120
Max. acceleration Z	m/s <sup>2</sup>	5.0	5.0	5.0	5.0	5.0	5.0	1.5	1.5
Repeat accuracy/axis +/-	mm	0.1	0.1	0.1	0.1	0.1	0.1	0.1	0.1

\*Version with higher load bearing capacity

# Z-Axes



Aluminium axis

Besides the standard version, Z-axes can also be designed for a high load bearing capacity (HD/STL). The LP 100 is also available as a High Speed (HS) model, which offers up to 80% faster axis acceleration in addition to higher speed.

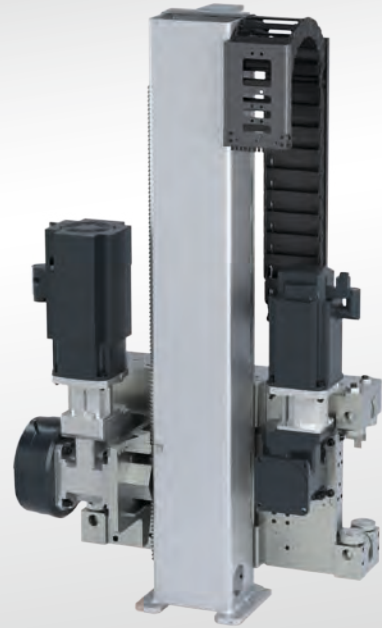

Steel axis

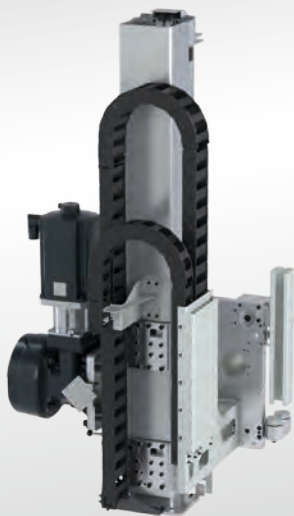

Telescopic axis

## Telescopic Axes - the Solution for low Hall Heights

In confined space conditions (e.g. low hall ceiling heights), telescopic axes expand the range of applications of conventional vertical axes. Liebherr telescopic axes achieve virtually the same payload with half the axis length, and have the same stiffness and positioning precision as the classic version.



# Flying Robot



Flying robot (articulated robot at gantry)

Flying robots (articulated robots at the gantry) can be used for more complex movements in the room. The 6- or 7-axis gantry robots combine the freedom of the articulated robot system with the benefits of linear robot technology (top loading, large working area). Depending on the individual task, the robots can be installed suspended, upright, or at the side of the gantry. We offer the flying robots independent of the robot manufacturer (e.g. KUKA, Fanuc, ABB). There are two sizes available with payloads up to 70 or 200 kg.



Top-mounted (7 axes)



Right-side mounted (6 axes)



Upside-down mounted (7 axes)



Left-side mounted (6 axes)

# Gripper Assembly

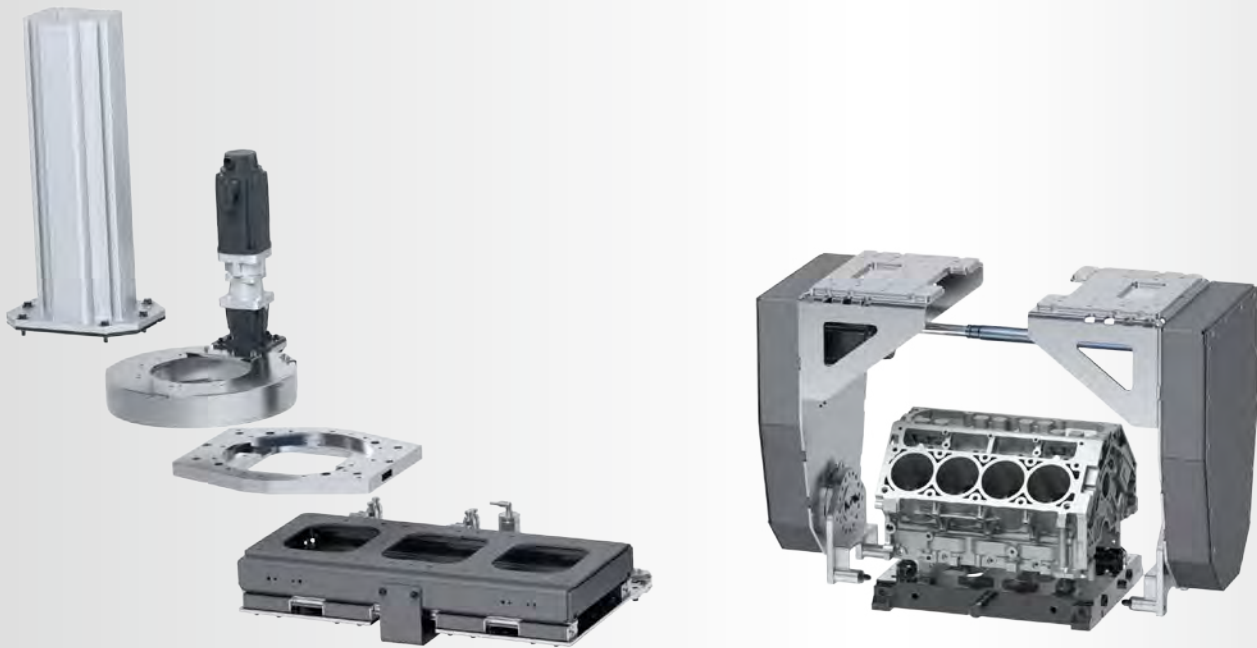

We can build on a comprehensive modular Liebherr gripper assembly for the range of parts to be automated. This way all necessary gripping and axis movements can be realized. Starting with the simple gripping movement for shafts and wheels through to complex turning and swivel movements in the cubic parts area. Here Liebherr combines basic components from well-known global manufacturers with the modular system developed by Liebherr. Where possible part variants are covered by a flexible gripper system which can be complemented if needed by a gripper change system.

## Application Examples



Pinion / Gear wheel



Crankshaft



Cylinder block



Cylinder block

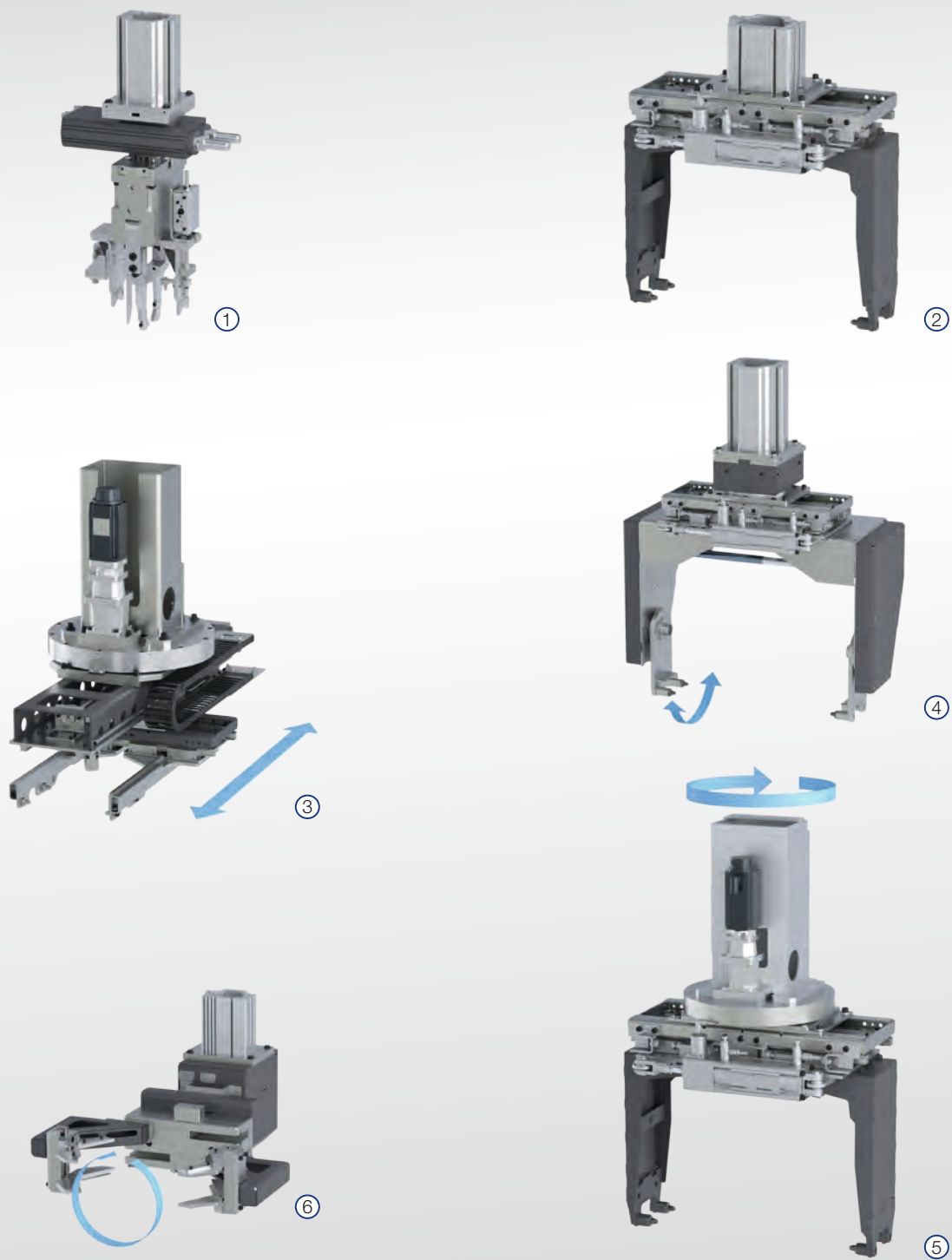

1 Crankshaft gripper · 2 Standard gripper for cubic parts · 3 Gripper for cubic parts with horizontal linear axis (Y-axis) · 4 Gripper for cubic parts with bucket axis (A-axis) · 5 Gripper for cubic parts with rotary axis (C-axis) · 6 Gripper for cubic parts with rotation axis (D-axis)

# Conveying Systems

In a variety of manufacturing systems ground automation is also required in addition to gantry technology to perform the task. This is often required for loading and unloading systems, decoupling machining operations, or for component transport. Liebherr offers a variety of belt conveyor systems which can be optimally adapted to the respective application.



## Friction Roller Conveyor (FRB)

With friction roller conveyors, workpieces can be transported directly or on pallets. In this case, the transport length can be extended as required by joining individual conveyor sections. The friction rollers are designed to not damage the part surface during transport.



## Plastic Chain Conveyor (KKB)

Plastic chain conveyors from Liebherr are designed to transport any number of irregularly shaped workpieces without them coming into contact with each other. Transportation of the workpieces is on pallets. Provides optimal solution for multiple machine cells with buffering requirements. Allows for flexible layout configurations.

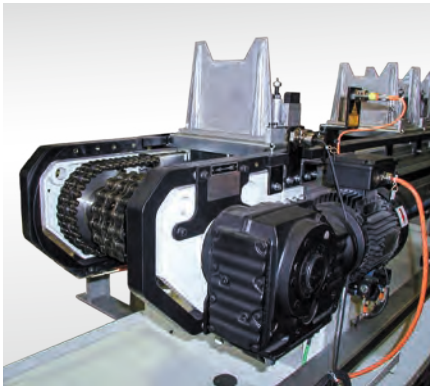

## Pallet Accumulating Conveyor (PSB)

Pallet accumulating conveyors also serve to transport any number of irregularly shaped workpieces without them coming into contact with each other. Here, too, transportation of the workpieces is on pallets. Empty pallets are returned on the underside of the conveyor to save floor space. Provides optimal solution for moving large parts between operations, with excellent buffer capacity.



## Section Roller Belt (SERB)

With section roller belts, workpieces can be transported directly or on pallets. They also have an automatic accumulating function which is not dependent on weight. Due to the queue effect they can be operated independently of cycles.



### Accumulating Conveyor (SFB)

Accumulating conveyors are designed to transport workpieces either directly or on pallets. By joining individual belt sections, the transport length can be extended to any length. Ideal conveyor solution for assembly or adapter plate processes.

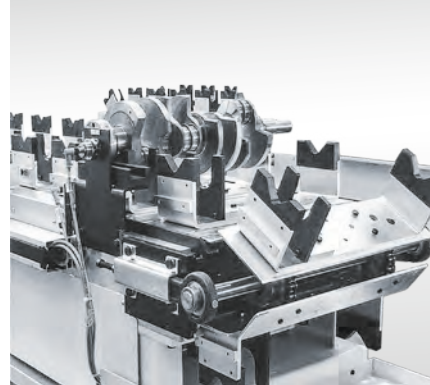

### Timer Chain Conveyor (TKB)

Timer chain conveyors serve to transport parts on workpiece carriers. These are permanently joined to the drive chain and are conveyed depending on the cycle.

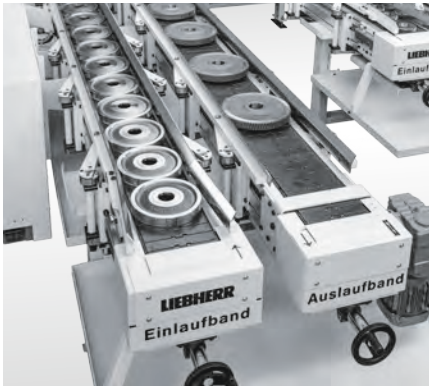

### Hinged Chain Conveyor (SKB)

With the aid of hinged chain conveyors, it is possible to transport workpieces with a flat surface, e.g. gear wheels. Depending on the scenario, multi-track versions are also possible. By joining individual belt sections, hinged chain conveyors can be extended to any length.

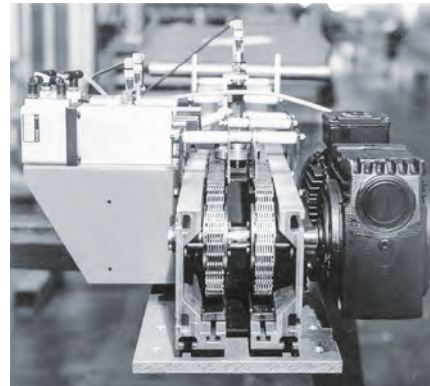

### Tooth Chain Conveyor (ZKB)

Tooth chain conveyors transport workpieces that do not have a flat surface, e.g. those with journals or shoulders. By joining individual belt sections, tooth chain conveyors can be extended to any length independently of cycles.

# Additional Equipment



Other tasks often have to be covered in manufacturing systems in addition to transportation. Whether it is the discharge of workpieces for the statistical process control, cleaning in order to avoid the carry-over of cooling lubricant, detection and tracking of workpieces in the manufacturing process, or labeling of a component with a data matrix code. For all of these tasks Liebherr can provide a suitable solution from its extensive range of peripheral equipment.



### Static Process Control

The statistical process control is a fixed element of any production line in modern production systems. Liebherr supplies these modular-based stations for discharge and inclusion of components.

Depending on the version, these units also offer the option of performing picker maintenance or retooling processes with minimal spatial requirement.



### Labeling Systems

With the high-quality labeling systems offered by Liebherr, digital combinations or codes can be lasered, etched, or engraved with needles on the workpiece.



### Camera Systems

With the aid of camera systems, labels and codes on the workpieces can be read and their information transferred to higher level production management systems.

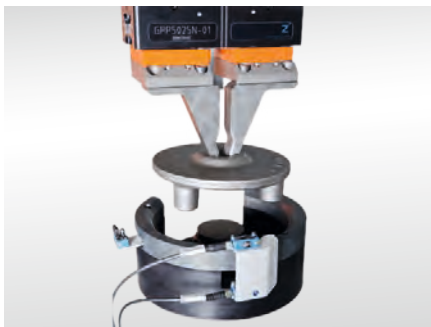

### Orientation Station

Modern production machines require that workpieces are loaded with the correct orientation. If the loading system is incapable of doing this, Liebherr offers ancillary orientation stations.



### Centrifugal Station

To prevent the displacement or mixing of cooling lubricants, it is necessary for the workpieces to be cleaned automatically. Depending on the needs of the customer and the workpiece, different processes are employed. The Liebherr modules include centrifuging, vacuum, and blow-off stations.

# Storage Systems



Storage systems for workpieces can be deployed in a variety of ways: Whether it is for loading/unloading function, decoupling module, in-process buffers or automated storage retrieval system.

## Shelf Magazine with Loading Gantry

The workpieces are stored directly in the shelves with the loading gantry. Here, the shelf magazine can be loaded either from the top or from the side. Thanks to the modular design, the complete system can be extended and, depending on the layout, enables storage based on the principle of "first in – first out".

## Decoupling Module (EKM)

The decoupling module serves as a means of storing and decoupling on flexible production lines. It features a high storage capacity with small surface area requirement and is suitable for a very wide range of workpieces and production concepts. The workpieces are placed on pallets in the decoupling module and made available via pull-out mechanisms for the gantry or robot systems to allow loading and unloading. A manual loading and unloading drawer for measuring parts can be included if required. The integrated control system with standardized Liebherr software facilitates commissioning and enables simple retrofitting on a production line.

## Palletizing Cell (LPC)

The palletizing cell provides an ideal means to implement decoupled automation systems for gears or other small parts. The LPC employs basket technology to standardize the manufacturing logistics for loading/unloading and material transport.



# Project Management



As a system supplier, Liebherr looks after the entire project planning including the clarification of machine specifications and interfaces with subcontractors. Each project is assigned to a project manager who assumes the entire order processing as the central contact person. We guarantee smooth running of the project by means of modern ERP and project management systems.

In cooperation with the customer, control books, interlock specifications, and sequences of operations are created in order to guarantee compliance with the applicable laws, standards, and guidelines. The content described is

considered to be design specifications for all manufacturers and suppliers involved in the project. The control architecture of the Liebherr automation systems is described in the control book taking into account the customer specifications. The interlock specification describes the interface between the Liebherr automation systems and the connected machines. The individual functions and the processes of Liebherr automation systems within the production line are described in the sequence of operations. As a result, Liebherr is able to assume responsibility for the CE conformity of the complete system.

# Sequence of Operations

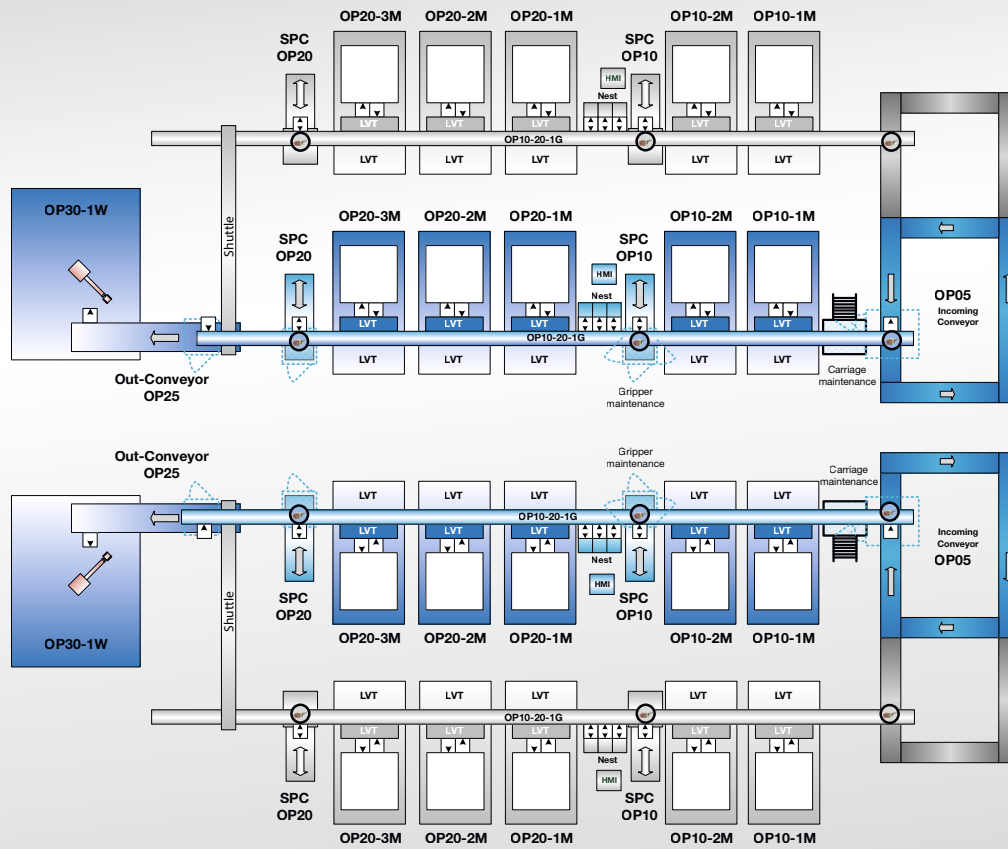

Block layout

The individual functions and the processes of Liebherr automation systems within the production line are described in the sequence of operations displayed as a block layout. The description includes all stations controlled directly and managed by the loading gantry cell control such as conveyor belts, marking stations, or camera systems. In this manual all operating modes, the safety functions, and the emergency strategies according to the machinery directive are described.

# Control and Technical Components

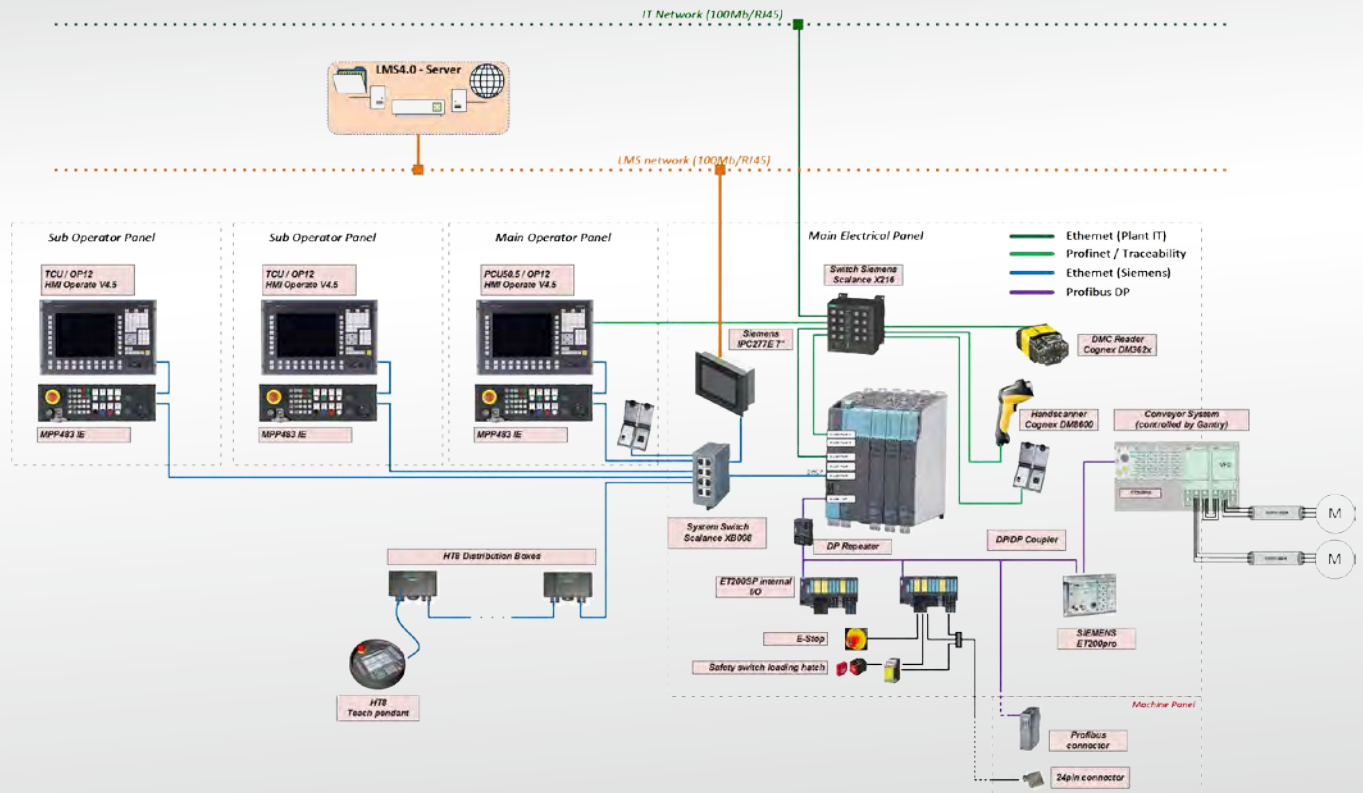

Control structure

## Control Books

The control architecture of the Liebherr automation systems as well as the selected electrical components are described in the control book taking into account the customer specifications.

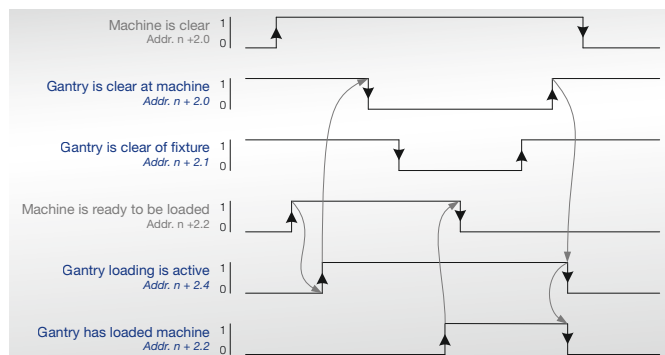

Signal-time diagram

## Interlock Specification

The interlock specification describes the electrical interface between the Liebherr automation systems and the connected machines and stations.

With a standardized software interface, a wide variety of processing machines, control or production planning systems can easily be integrated. This interface is the basis for the realization of short commissioning times, as well as trouble-free operation, and simple maintenance throughout the entire product life cycle.

# Industry 4.0

## Liebherr Manufacturing System (LMS 4.0)

### Production Schedule App

Management of production orders and processes

### Production Monitoring App

Recording production and operating data



### Part Tracking App

Guarantee a safe process within the production or assembly line as well as long-term parts tracking

### Info Board App

Display of the machine status on a large screen or on mobile end devices

### Liebherr Manufacturing System (LMS 4.0)

Complex production systems require increased functionality in their software systems. With the Liebherr Manufacturing System, Liebherr offers user-friendly additional software which guarantees process reliability in a production or assembly line. The basic software can be flexibly adapted to the respective customer requirements using apps.

LMS 4.0 is capable of logging a retracing of parts as well as securing specific data and making this available to all users participating in the system. The system offers a variety of evaluations. For instance, the Production Monitoring App can be used to monitor the correct compliance with the manufacturing process. A new dataset is created in LMS the first time the workpiece is placed on the production line. The dataset is continuously updated after every step. If the workpiece leaves the production line in the normal way, then the dataset is archived chronologically in the long-term memory. If a workpiece is fed back to the line following a check via a SPC station, then LMS first checks whether the workpiece has the specific production level and rejects the release for the inclusion of the workpiece at the corresponding SPC station.

The Production Schedule App offers the option of processing production orders according to priorities. This can be done statistically (e.g. one after another or also dynamically on the final date).

Thanks to the extension with new functions such as "Production Monitoring App" and "Info Board App", the processes can be easily displayed on large screens or on mobile end devices. Numerous useful features such as an E-mail Client, which automatically sends e-mails to a distribution list as soon as an error or a warning occurs, round off the system.



Video: LMS 4.0

# Health & Safety, Environment



We are a certified company according to ISO 9001, ISO 14001, and OHSAS 18001. With help of our HSE Department (HSE = Health & Safety, Environment), we guarantee a high standard in occupational safety, health, and environment protection to our customers as well as within the organization.

Our measures exceed regulations laid down by the legislator. Our Total Safety approach aims to identify, correct, and avoid health, safety, and environmental risks in advance which may have a negative effect on employees and customers. For this reason our HSE Team monitors strict compliance with our guidelines in order to achieve the ultimate goal of "zero accidents".

Our H&S Team has many years of experience and works according to the principle of the continuous improvement process. With the use of standard tools such as FMEA (Failure Modes and Effects Analysis), possible causes can be analyzed in advance and appropriate measures introduced. During regular visits to the customer the H&S Team can compile risk assessments and initiate the appropriate measures to minimize the risk at the workplace. Strict compliance with environmental and safety regulations by all employees, as well as individual responsibility, are elements of our corporate culture.

# Preventive Maintenance

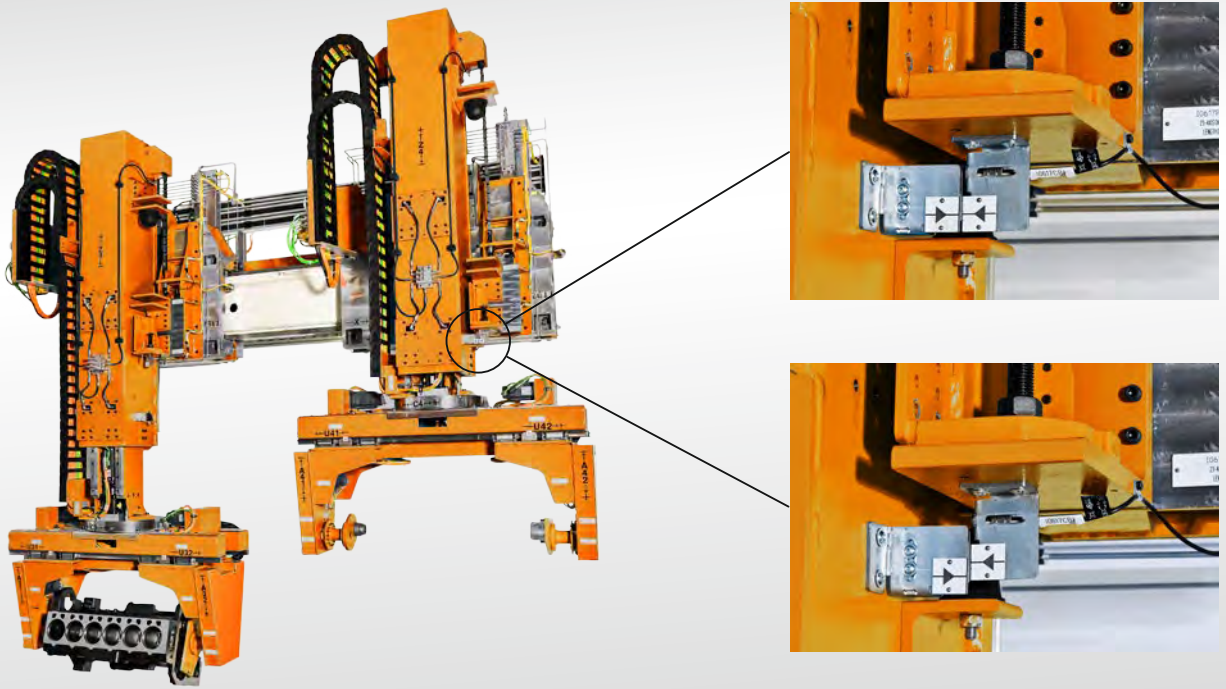

Online system monitoring via target/actual comparison

## Preventive Maintenance

Preventive maintenance makes possible the reduction of machine downtimes, the improvement of machine utilization and plant safety, and the decrease of maintenance costs. By means of time- or interval-based maintenance planning, critical components are replaced in good time before the wear becomes critical.

## Predictive Maintenance

The plant condition can be monitored online using existing and additional sensor technology and preventive maintenance can be introduced in good time in the event of deviation to predefined tolerance limits.

## Example: Chain Wear Measurement

The chain wear measurement regularly measures the wear elongation of the telescopic axle chains during operation. The target/actual position of the retracted telescopic axle is scanned using a reference switch. Maintenance recommendation is displayed, once the tolerance range is exceeded.

# System Monitoring

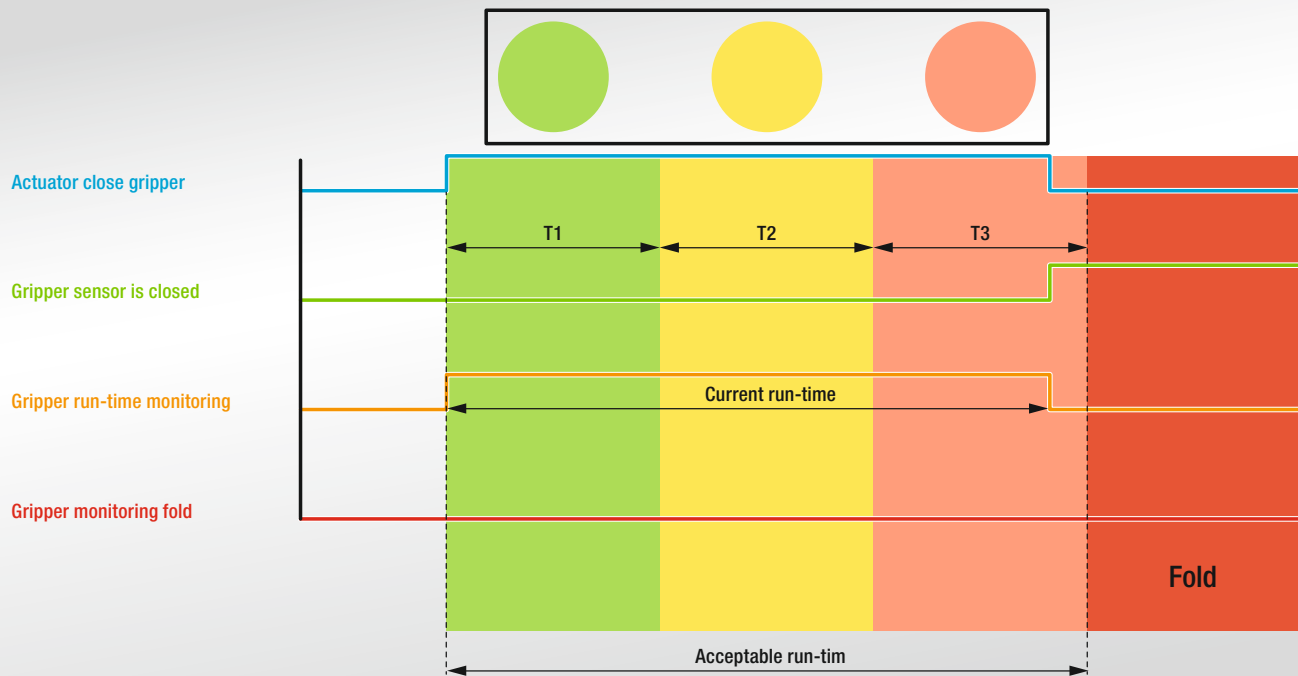

Run-time and limit switch monitoring

## Example: Extended Gripper Monitoring

The extended maintenance is based on run-time and limit switch monitoring. Three time slots are defined which are still within the permissible run-time:

Time slot T1 defines an optimal movement:

● green area → no action required

Time slot T2 defines a slightly deviating trend:

● yellow area → check on occasion

Time slot T3 defines a widely deviating trend

● bright red area → The component should/must be checked at the next unproductive phase

Run-time exceeded beyond time slot T3

● dark red area → error / machine stops

# Machine and System Solution

Our core area is the delivery of turkey system solutions for manufacturing systems. As a complete provider, we integrate all upstream, intermediate, and downstream processes into the overall concept according to customer requirements. The international collaboration with leading manufacturers of machine tools revealed invaluable potential for operational experience, from which all customers now benefit.

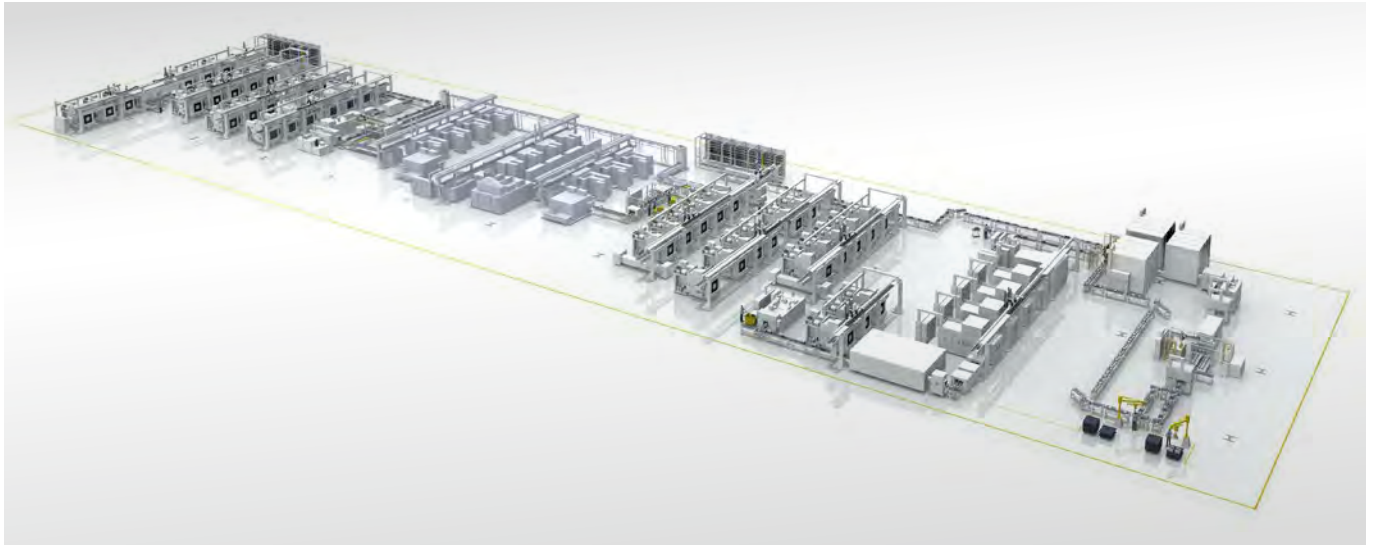

OEM Automotive, China. Source: MAG IAS GmbH



Liebherr gear cutting machines with gantry robot automation





Ford engine block line



Ford engine block line



Ford engine block line

# Service and Locations

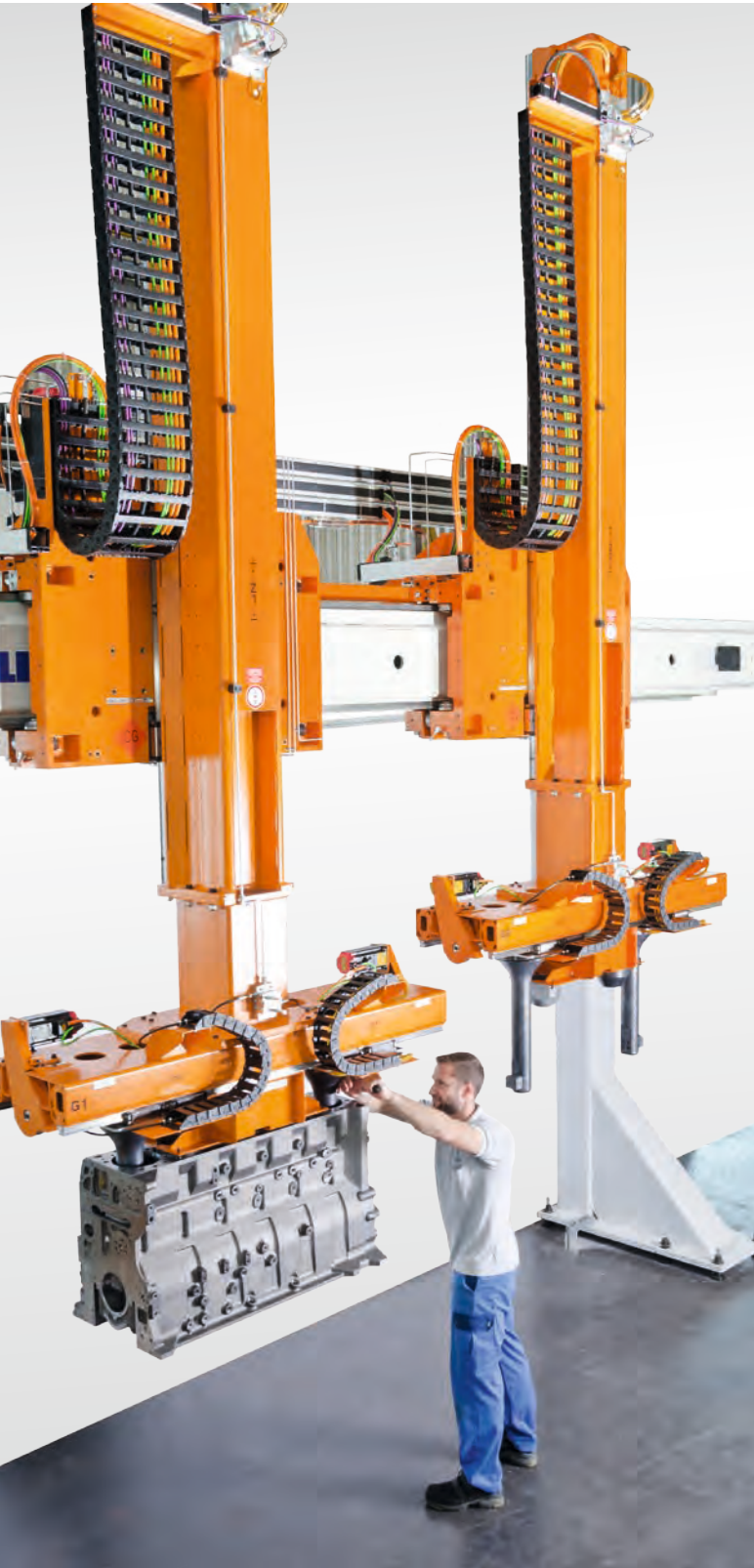

## Training

We offer a comprehensive range of training courses both at the customer's premises and in our subsidiaries. The practical technical training courses are delivered by our experienced system technicians who are very familiar with the systems and applications owing to their many years of experience. These training courses enable you to help yourself and use systems safely in emergency situations, e.g. a power failure.

## Customer Hotline and Remote Maintenance

Our experts who man the customer hotline provide professional initial assistance when needed. Many faults can be eliminated with the support of our experts via remote access.

## Global Presence and Spare Parts Availability

With our headquarters in Kempten and global subsidiaries, as well as service outlets, we guarantee a fast response time in order to be able to deploy a service technician to the customer's premises if necessary. A rapid replacement parts service is guaranteed thanks to the consistent modular system of the products and the use of basic components from well-known, global manufacturers. Original spare parts are stocked in the subsidiaries and can be delivered to your production sites within a short period of time. Included in the services offered are the provision of spare parts, inspections, maintenance or modifications to systems.

## Service and Maintenance

Liebherr developed a system for optimizing repair and maintenance based on experiences with aerospace components within the Liebherr Group. As a result of this, maximum availability values and minimal total costs of ownership are achieved.

Most of the unexpected system failures can be avoided through preventive maintenance.

We also offer our customers optional "Wellness Checks" to minimize the risk of machine downtimes and secure the

machine availability over the long term. Axles, gearboxes, cable drag, guides, carriages, as well as cables and hoses, are checked and replaced if necessary.

The system data is saved as a backup during each service and maintenance call in order to restore the status of the last maintenance if needed and thus quickly guarantee the restart of production.



### Locations of Liebherr-Verzahntechnik

- Liebherr-Verzahntechnik GmbH, Kempten, Germany
- Liebherr-Verzahntechnik GmbH, Ettlingen, Germany
- Liebherr-Utensili S.r.l., Collegno, Italy
- Liebherr-Verzahntechnik Paris, France
- Liebherr-Rusland OOO, Moscow, Russia
- Liebherr-Gear Technology Inc. and Liebherr Automation Systems Co., Saline, USA
- Liebherr Brasil Guindastes e Máquinas Operatrizes Ltda., São Paulo, Brazil
- Liebherr-Machine Tools India Private Limited, Bangalore, India
- Liebherr Machinery Service (Shanghai) Co. Ltd., China
- Liebherr Japan, Tokyo, Japan
- Liebherr Machine Tools and Automation, Seoul, South Korea

# Machine Tools and Automation Systems from Liebherr

Liebherr employs roughly 1200 staff in the area of machine tools and automation technology and has production facilities in Kempten and Ettlingen (Germany), Collegno (Italy), Saline (Michigan, USA) and Bangalore (India). They are supported by expert and reliable marketing and service specialists at a large number of locations worldwide.

With over sixty years of industrial experience, Liebherr is one of the world's leading manufacturers of CNC gear cutting machines, gear cutting tools and automation systems. The company's innovative products are the result of pioneering ideas, highly qualified staff and state-of-the-art manufacturing systems at each of their locations. They are characterised by economy, ease of use, quality and reliability in combination with a high degree of flexibility.



## System Solutions in the Area of Machine Tools

Included in the production programme are gear hobbing machines, gear shaping machines and generating- and profile grinding-machines, all noted for their high degree of stability and availability. Particular importance is attached to the energy efficiency of the machines.

Gear cutting machines from Liebherr are supplied to renowned manufacturers of gears and gearboxes and large-scale slewing rings worldwide. They are in demand primarily from the automotive and construction machinery industries and also increasingly from the wind power industry for the manufacture of gears for wind turbines.

## High Quality Gear Cutting Tools

Liebherr manufactures high quality, precision tools for the soft and hard machining of gears and all Liebherr gear cutting machines are fitted with Liebherr tools. The range also includes Lorenz shaping tools and products customised for specific customer applications.

## Automation Systems for a Broad Range of Applications

Liebherr has a wide range of products for linear robots, pallet-handling systems, conveying systems and robot integration for projects in all areas of production and can provide above-average availability of systems.

[www.liebherr.com](http://www.liebherr.com)

**Liebherr-Verzahntechnik GmbH**  
Werk Ettlingen  
Gear Cutting Tools  
Hertzstraße 9-15  
76275 Ettlingen, Deutschland  
☎ +49 (0)7243 708-0  
Fax +49 (0)7243 708-685  
[tools.lvt@liebherr.com](mailto:tools.lvt@liebherr.com)

**Liebherr-Utensili S.r.l.**  
Gear Technology  
Via Nazioni Unite 18  
10093 Collegno TO, Italien  
☎ +39 (0)114 248711  
Fax +39 (0)114 559964  
[info.lut@liebherr.com](mailto:info.lut@liebherr.com)

**Liebherr-Gear Technology Inc.**  
Gear Technology  
**Liebherr Automation Systems Co.**  
Automation Systems  
1465 Woodland Drive  
Saline, MI 48176-1259, USA  
☎ +1 7344 297225  
Fax +1 7344 292294  
[info.lgt@liebherr.com](mailto:info.lgt@liebherr.com)

**Liebherr-Machine Tools India Pvt. Ltd**  
Gear Technology  
353/354, 4th Main, 9th Cross,  
4th Phase  
Peenya Industrial Area  
Bangalore - 560 058, Indien  
☎ +91 (0)80 41 273033  
Fax +91 (0)80 41 272625  
[info.mti@liebherr.com](mailto:info.mti@liebherr.com)

**Liebherr-Verzahntechnik GmbH**  
Verzahntechnik und Automationssysteme  
Kaufbeurer Straße 141, D-87437 Kempten  
☎ +49 (0)831 786-0, Fax +49 (0)831 786-1279  
[www.liebherr.com](http://www.liebherr.com), E-Mail: [info.lvt@liebherr.com](mailto:info.lvt@liebherr.com)